

PROFILES

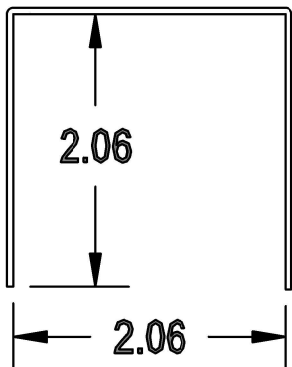

PROFILE "A"

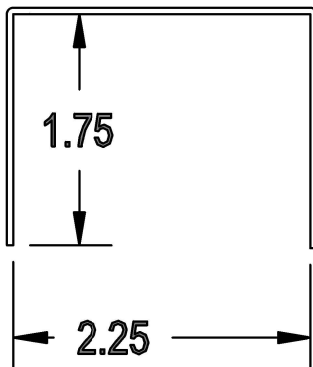

PROFILE "B"

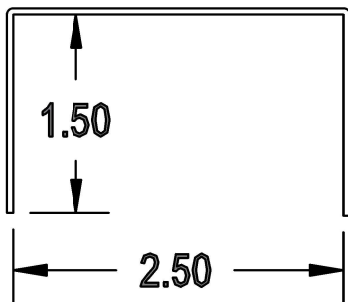

PROFILE "C"

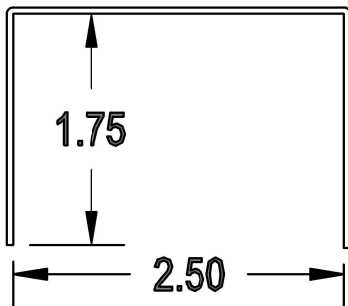

PROFILE "D"

<u>PART #</u>	<u>LENGTH</u>
CH08-A2	2'-0"
CH08-A4	4'-0"
CH08-A6	6'-0"
CH08-A8	8'-0"
CH08-B2	2'-0"
CH08-B4	4'-0"
CH08-B6	6'-0"
CH08-B8	8'-0"
CH08-C2	2'-0"
CH08-C4	4'-0"
CH08-C6	6'-0"
CH08-C8	8'-0"
CH08-D2	2'-0"
CH08-D4	4'-0"
CH08-D6	6'-0"
CH08-D8	8'-0"

TOLER. UNLESS SPECIFIED:		CH MACHINE	
ANGLES:	± 0' 30'	P.O. BOX 588	
FRACTIONS:	± 1/64	VERNON, ALABAMA 35592	
2 PLACE DECIMALS:	± .010	TITLE:	
3 PLACE DECIMALS:	± .005	CH08 BRACES	
REF.:		SIZE:	REV:
DATE:		B	1
DRAWN BY:		SCALE: 1=1	SHEET 1 OF 1
		DRAWN BY:	
		REFERENCE:	